

### Introduction

The Vacuum Degasser is a high-efficiency in-line module that removes dissolved gasses from HPLC solvents. Its unique design assures reliable continuous operation and the highest level of continuous performance available without the need for helium degassing. Up to five solvent lines may be degassed simultaneously by one unit. The extremely low internal volume of each channel offers very quick equilibration and very short startup times compared with PTFE degassing channels which have the same degassing efficiency.

Inside the unit, the solvent flows through a short length of tubing which is located in a vacuum chamber. Within this chamber a partial vacuum is maintained by a constantly running, low RPM vacuum pump. Dissolved gasses migrate across the tubing wall under a concentration gradient produced by the vacuum as the solvent flows within the coil. Gasses removed are expelled, and the chamber is maintained at a constant, preset vacuum level by varying the vacuum pump speed as needed.

A special port in the vacuum pump continually flushes the pump head with a small “bleed” of air to remove any solvent vapors which may enter the pump from the vacuum chamber. This air bleed eliminates the need for any solenoid valves within the system. This patented\* design results in zero vacuum “hysteresis”. Previous designs allowed the vacuum chamber pressure to fluctuate, with the pump cycling on and then off in response to the vacuum level.

\*This product is protected under U.S. patents 6,494,938; 6,248,157; 5,340,384 and 5,006,382. Other patents pending.

## Front Panel Connections

Depending upon the model, there are from 1 to 5 degassing channels. Pairs of female ¼-28 connectors are located on the front of the Vacuum Degasser cabinet. These are the input and output ports for running up to 5 solvent lines through the Vacuum Degasser. Each channel has an input port and an output port on the same level, labeled on the front panel as “A” through “E”. Flow direction is not critical. Plugs are provided to seal the ports of unused channels.

## Front Panel Indicators

Three LEDs are located on the front of the instrument above the solvent inlets and outlets:

### POWER (Green)

Indicates when power is applied to the Vacuum Degasser (plugged in and Power switch ON).

### STATUS (Yellow)

Indicates when vacuum level is outside acceptable operating range. Normally it will come on at initial power-up and remain on during pump-down. It will go off in a few minutes when the vacuum level goes below 100 mm of Hg absolute. If an error condition occurs, this LED will flash in one of two modes:

- Flashing on and off in even 1-second intervals: pump was not able to reach vacuum set point, indicating a possible leak in the system.
- Flashing on for 1 second and off for 2 seconds indicates a vacuum signal error.

### VACUUM (Green)

Indicates when vacuum level is within acceptable operating range. Normally it will come on after the initial pump-down, and remain on as long as the Vacuum Degasser is powered up and vacuum level is below 100 mm of Hg absolute.

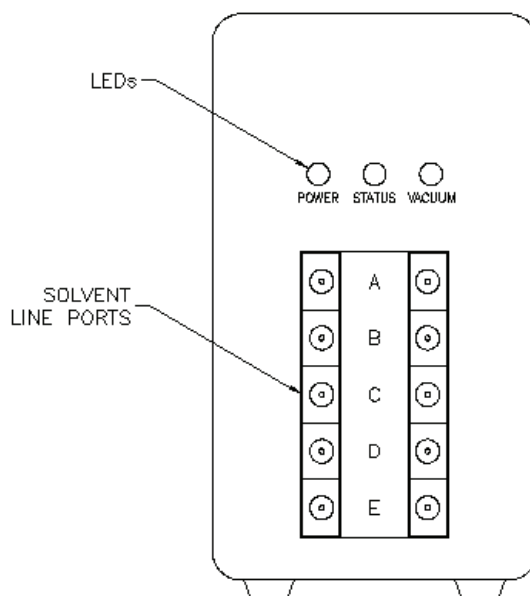

**Figure 1. Front view of 5-Channel Vacuum Degasser**

## Rear Panel Connections and Controls

### Exhaust Port

The gas pumped out of the vacuum chamber leaves the unit through the exhaust port.

### Power Receptacle

The power receptacle accepts the DC plug of the supplied AC Adapter. See Specifications section for further power requirement information.

### Power Switch

This On/Off rocker type switch applies line power to the Vacuum Degasser. The rocker indicators are as follows: “O” = Off and “|” = On.

### Validation Connector (Optional)

Depending on the model, there may be a 2-pin receptacle labeled “Validation” located next to the power switch. This receptacle and its mating screw-lock plug allow a validation signal from the Vacuum Degasser’s control circuit to be sent to a computer or data system. This validation output indicates vacuum level (see Specifications section for details).

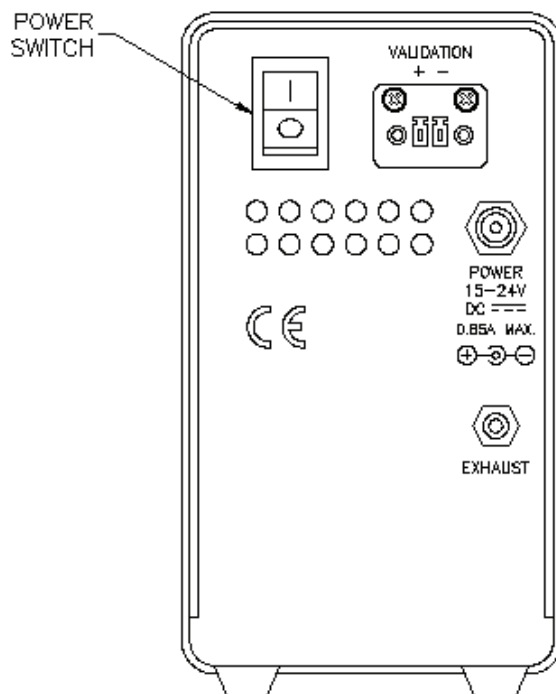

**Figure 2. Rear view of Vacuum Degasser**

## Specifications

Specification	Description
Dimensions:	Height: 5.0 in. Width: 2.87 in. Depth: 9.81 in.
Weight:	6 lb.
Channels	1-5 Independent
Degassing Process	Gas permeation through a fluoropolymer membrane
Maximum Recommended Flow Rate <sup>1</sup>	3.0 mL/min.
Pressure Drop <sup>2</sup>	1.37 mm Hg/mL/min.
Degassing Capacity	~25% dissolved gases remaining in 60:40 MeOH/Water mixture at 1 mL/min.
Dead Volume	~480 microliters per channel for standard channel
Materials contacting solvents	PEEK, Glass-filled PTFE, Systec AF™
Power:	
Power requirement if using supplied AC Adapter	100 to 240 VAC (±10%), 1A, 50 to 60 Hz (±3 Hz)
Power Requirement if <u>not</u> using supplied AC Adapter	15 to 24 VDC at 0.85 A maximum (0.5 A typical)
Wall Sockets	4 supplied with AC adapter, interchangeable: North America/Japan, U.K., Continental Europe, Australia
Installation Over-Voltage Category	II
Validation Output:	
Signal	5 m VDC / 1 mm Hg absolute from 20 to 800 mm Hg (0.100 VDC at 20 mm Hg; 4.000 VDC at 800 mm Hg)
Accuracy	±1.0% of reading ±0.010 VDC from 20 to 800 mm Hg
Operating Conditions:	
Ambient Temperature	10 to 35 °C
Ambient Relative Humidity (RH)	20 to 80 % RH (without condensation)
Altitude	0 to 2000 Meters
Indoor vs. Outdoor Use	Indoor
Pollution Degree	2
Storage Conditions:	
Ambient temperature	-20 to +60 °C
Ambient Relative Humidity	20 to 80% RH (without condensation)
Altitude	0 to 12000 M

1 Maximum recommended flow rate to prevent a 60:40 MeOH/Water mixture from outgassing. The estimate assumes low pressure mixing and low flow restriction prior to the HPLC pump. MeOH/Water mixing represents the worst outgassing case and maximum flow rate will likely increase with Acetonitrile/Water mixtures. High pressure mixing will also increase the maximum flow rate. Degassing is still recommended.

2 Calculated tubing pressure per unit change in flow assuming laminar flow with a viscosity of 1.0 cP. Inlet and outlet bulkheads may contribute to the overall pressure, but are not included in the estimate.

## Unpacking the Vacuum Degasser

Carefully unpack the Vacuum Degasser and check for obvious signs of damage that may have occurred during shipment. Immediately report any damage or missing items to your Service Representative.

### Items supplied with the Vacuum Degasser:

Item	Quantity
AC Adapter (including cord)	1
Interchangeable Wall Plugs	4 (North America/Japan, U.K., Continental Europe, Australia)
Operator's Manual	1
Plug, 1/4-28, Rheodyne 6118	2

## System Requirements

### Solvents/Mobile Phase

Use only HPLC grade solvents in all analyses.

#### CAUTION

The degassing membrane in the Vacuum Degasser is manufactured from Systec AF™. As with older membranes manufactured from PTFE, Systec AF™ is inert to all solvents normally used in HPLC. However, Systec AF™ is soluble in perfluorinated solvents such as Fluorinert® FC-75 and FC-40 and Fomblin perfluoro polyether solvents from Ausimont. In addition, Freon® solvents will adversely affect Systec AF™. Use of such solvents in the Vacuum Degasser will result in the dissolution and hence destruction of the membrane.

#### CAUTION

Use proper care when handling flammable solvents. Make sure that there are no leaks in the solvent lines (see Operation section, page 8, step 2). Ensure that hazardous exhaust gases are properly vented.

### Corrosion

All parts that contact the mobile phase are made of PEEK, Glass-filled PTFE or Systec AF™. PEEK is sensitive to Sulfuric acid and certain solvents.

### Space Requirements:

The Vacuum Degasser is designed to sit on a bench top, and is plumbed into the LC system between the solvent supply and pump. A space 5¼ in. high and 3 in. wide is sufficient. The case is about 10 inches deep (front to back), but additional space is required both in front, to accommodate the tubing connected to the unit, and behind to accommodate the cord.

### Electrical Power Requirements

The AC Adapter supplied with the Vacuum Degasser incorporates a universal AC input, switching regulator. This allows the instrument to operate at any AC line voltage from 100 to 240 VAC (±10%) with a line frequency range of 47 to 63 Hz. The switching regulator senses the incoming line voltage and automatically adjusts its operation accordingly. The switching regulator assembly

incorporates its own on-board line voltage fuse. This fuse is not user serviceable. In the event that this fuse blows, it will be necessary to replace the AC Adapter.

A set of four interchangeable wall plugs is included to allow the AC adapter to be plugged into the standard electrical sockets in North America, Japan, the U.K., most countries in continental Europe, and Australia.

It is recommended that the AC Adapter be used to supply power to the Vacuum Degasser. If another means is used to supply power to the rear panel power jack, the voltage must be within the range 15 to 24 VDC at 0.85 A maximum (0.5 A typical). The rear panel power jack will accept a 2.1 mm female plug. Correct polarity must be observed. The center connection of the plug must be positive, and the outside must be negative. See figure below.

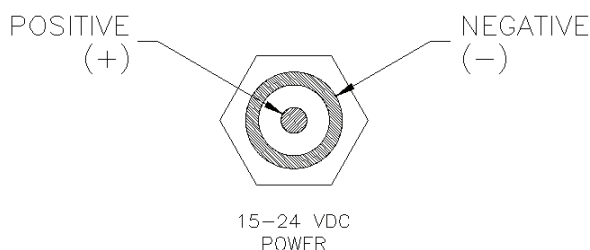

**Figure 3. Rear Panel Power Connector Polarity**

## Setup

### Installing the AC Adapter with Power Cord

Locate the AC Adapter with power cord and the set of four interchangeable wall plugs. Plug the round connector at the other end of the AC Adapter's cord into the Power jack on the Vacuum Degasser rear panel. From the set of four plugs, select the one appropriate for the local electrical socket and install it onto the AC adapter. With the power switch off, insert plug into the AC supply. The AC adapter should be positioned for easy disconnection.

### Connecting the Tubing

Solvent lines to be degassed are connected to the Vacuum Degasser's front panel ports, as detailed below. Unused ports must be plugged to enable the degasser to operate at its peak level of performance.

To make a tubing connection:

1. Run a line of 1/8" O.D. x 1/16" I.D. Teflon chromatography tubing from the solvent supply to the Vacuum Degasser.
2. Push the tubing through a PEEK 1/8" male 1/4-28 fitting and slide a ferrule over the tubing end (see figure below). Cut the Teflon tubing so the end is flat.

3. Screw the 1/4-28 fitting into one port on the front of the Vacuum Degasser (Channel A, for example). The direction of flow through the Vacuum Degasser is not critical. Plastic connectors should be tightened by hand. Overtightening them will damage the threads.
4. Repeat steps 1 through 3 to connect additional lines to be degassed.
5. Once all desired solvent lines have been connected to the Vacuum Degasser, any and all unused ports should be plugged. Use the plugs supplied. Press in by hand.
6. Prime each degassing membrane by pulling the solvent from the reservoir through the degassing system. This can be done by connecting a syringe to the tubing or LC pump priming port and drawing air and/or mobile phase into the syringe until no air remains in the tubing, approximately 5 milliliters.

**CAUTION: DO NOT** prime the membranes by pushing solvent through the degassing systems. This technique can generate several hundred pounds of pressure which might rupture the membrane. The maximum recommended pressure on the membrane is 0.48 mPa (70 psig, 4.8 Bar).

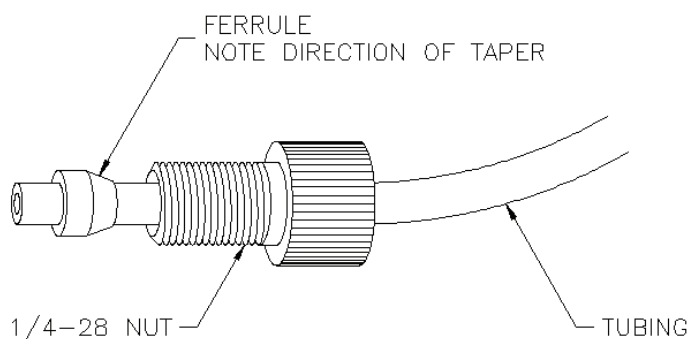

**Figure 4. Configuration of 1/4-28 Nut, Ferrule and Tubing**

### **Connecting the Vacuum Degasser in a Typical System**

The following illustration shows the tubing connections that are typically made between the Vacuum Degasser and other instruments in an LC system. The direction of flow through the Vacuum Degasser is not critical.

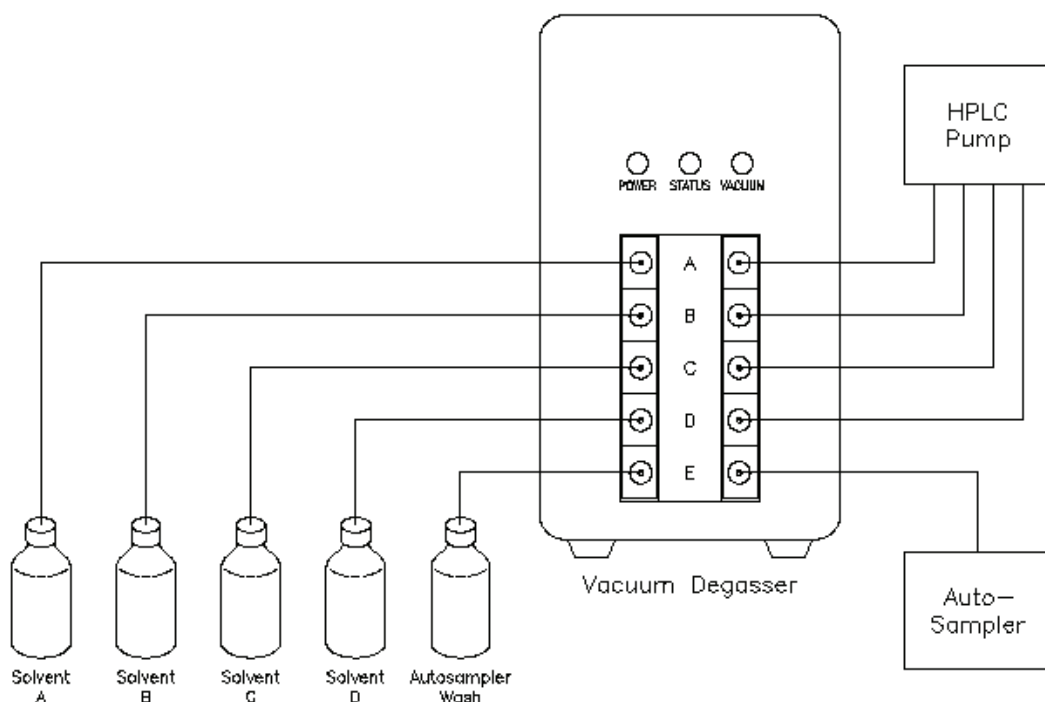

**Figure 5. System Tubing Connections**

## Operation

### Powering up the Vacuum Degasser

1. With the Vacuum Degasser plumbed into the system and the power cord installed, as described in the above section, flip on the rear panel power switch. The green Power LED should illuminate.

Immediately upon turning on the instrument, the microprocessor examines the vacuum sensor signal to confirm that it is within an expected range. Following the startup test, the microprocessor ramps the vacuum pump to high RPM, to quickly exhaust atmosphere from the vacuum chamber. As the vacuum level approaches the preset control value, the pump RPM will slowly ramp down to a low speed (typically 40 to 60 RPM) and will vary slightly as needed under the changing degassing load to maintain a virtually constant vacuum level.

During initial pump-down, the yellow Status LED will be lit. Once the vacuum has reached normal operating level, the yellow LED will extinguish and the green Vacuum LED will illuminate. If you want to confirm that the pump is running, beyond the front panel LEDs, the slight vibration caused by the microstepping of the motor driving the vacuum pump may be felt by placing your hand on the instrument.

2. Start solvent flow through the system and check for leaks around the 1/4-28 connectors.

If a leak occurs at the connection, tighten the fitting an additional 1/8 turn. If the leak persists, disconnect the leaking fitting and inspect it. If the nut and ferrule appear to be in good condition,



reconnect the fitting. If the leak persists, replace the nut and ferrule and repeat the procedure until you achieve leak-free operation.

The Vacuum Degasser maintains a constant vacuum pressure of 50 mm Hg absolute (nominal) by varying the speed of the vacuum pump as needed depending on the degassing load in the system. The pump is designed for at least 5 years of constant running and has integral in-pump venting, which eliminates the need for stop-start running (U.S. Patent 6,248,157). The vacuum level and pump speed is constantly monitored by the microprocessor for changes in operating conditions which might be attributed to chamber internal leaks. If a potential leak is detected, the pump will be shut down and the yellow Status LED will flash. The vacuum is maintained as long as the Vacuum Degasser is powered on. Solvent flowing through the Vacuum Degasser will continue to be degassed so long as the instrument is on and running.

3. Turn off the Vacuum Degasser when the LC to which it is connected is not in use. The vacuum chamber(s) will slowly return to atmospheric pressure when the unit is powered off. This is accomplished by a small, in-line vacuum bleed and reduces the possibility of solvent vapors condensing in the vacuum tubing or pump head.
4. When flushing a line of solvent, the single lumen coil inside the chamber contains a very small amount of solvent (approximately 480 microliters). When changing from one solvent to another where the final solvent is immiscible with the first, use an intermediate solvent miscible with both the initial and final solvent. Carryover from solvent to solvent is much less than previous PTFE designs. Once air bubbles have been cleared from the solvent line, any further bubbles observed will be coming from the solvent reservoir or from a leaking fitting.

NOTE: Since there is virtually no solvent retained within the Vacuum Degasser (~480 microliters per channel), priming the system is relatively simple. Using the Prime mode on the LC system pump, allow the pump to draw each solvent to be used in the analysis at a flow rate of 2 mL/min. for 1-2 minutes. This ensures that the line from the degasser channel being primed through the proportioning valve on the pump has freshly degassed solvent. This dynamic priming method will allow an immediate startup of the analysis upon column equilibration. Contrary to previous PTFE-based degassers, the new Vacuum Degasser fully degasses solvents within the time it takes for the volume to pass through the chamber, and yet degasses the solvents as thoroughly as, or better than, PTFE channels containing 40 times more solvent.

## Principles of Operation

The Vacuum Degasser consists of a vacuum chamber, degassing tube, variable speed vacuum pump, microprocessor controller, sensor, and check valves. The solvent (mobile phase) flows into a degassing tube, which is inside a vacuum chamber. Decreased pressure in the chamber causes the outward movement of gas dissolved in the mobile phase across the tube wall, in accordance to Henry's Law, thus degassing the mobile phase. The pressure in the vacuum chamber is established by the vacuum pump and monitored by the microprocessor through an integrated absolute pressure sensor. Degassed mobile phase exits the vacuum degasser and enters the pump.

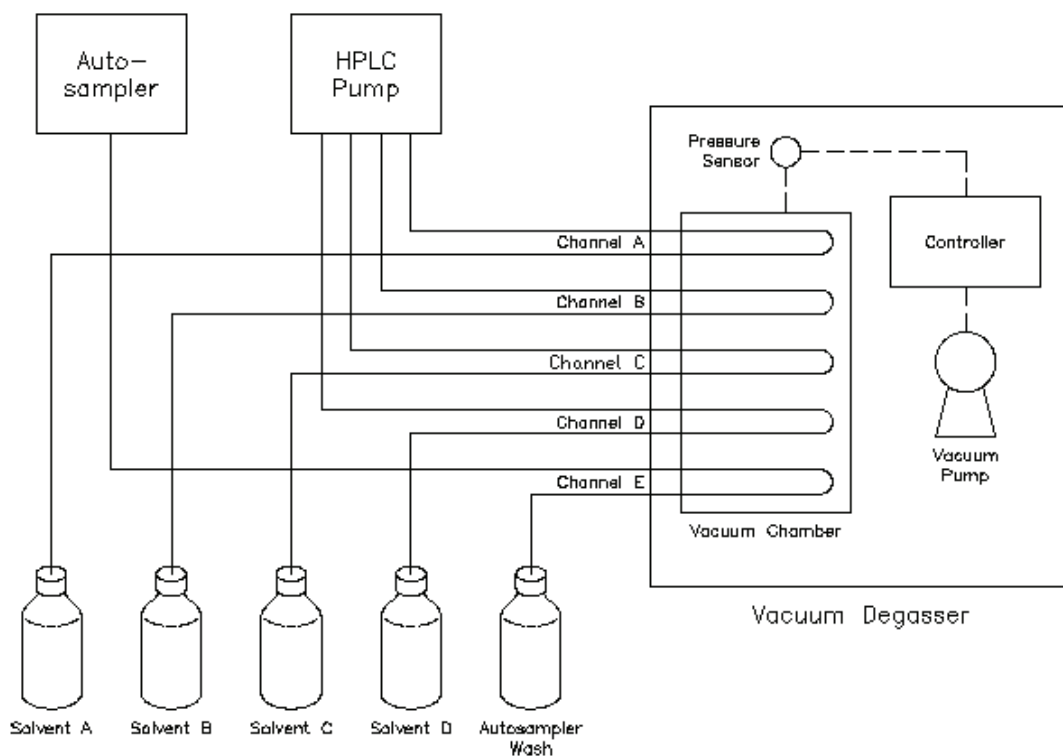

**Figure 6. Block diagram of Vacuum Degasser**

### Start Up Test and Pump Operation

Immediately upon turning on the instrument, the microprocessor examines the vacuum sensor signal to confirm that it is within an expected range. Following the startup test, the microprocessor ramps the vacuum pump to high RPM, to quickly exhaust atmosphere from the vacuum chamber. As the vacuum level approaches the preset control value, the pump RPM will slowly ramp down to a low speed (typically 40 to 60 RPM). Afterwards, the pump RPM will vary slightly, as needed under the changing degassing load, to maintain a virtually constant vacuum level ( $50 \pm 0.5$  mm Hg). This "zero hysteresis, constant run" mode is necessary, due to the extremely low mass, high response, degassing tubing. Only this design ensures a baseline which is unaffected by the degasser.

### Smart Leak Detection

An additional benefit of maintaining a constant vacuum level is that a potential leak in the vacuum degassing system can be observed by monitoring the RPM of the pump. This "smart leak detection"

is a benefit of the patented design of the degasser. If a leak occurs within the chamber, the microprocessor will increase the pump RPM in an attempt to maintain the vacuum level. If the pump cannot maintain the vacuum level (if it runs at an elevated RPM for more than 2 minutes), the yellow LED will flash, indicating a possible leak condition, and the system will shut down and go into a “safe” mode.

### **Principles of degassing using Systec AF™ membranes**

This relatively recent addition to the field of degassing has properties not found in other fluoropolymers. The fully amorphous nature of this fluoropolymer and its molecular structure creates a molecular level porosity unlike the mechanically induced porosity in PTFE extruded tubing. In addition, unlike the process used in extruding PTFE, no extrusion agents are needed (like kerosene, etc.) which contaminate mobile phases until they are extracted by the mobile phase over time. Likewise, this molecular structure, combined with the very small surface areas required to degas the mobile phase, reduces the possibility of carryover from one solvent or mobile phase to another to virtually zero.

Systec AF™ is so non-polar that it is both solvophobic and hydrophobic. This feature of Systec AF™ reduces the possibility of cross-channel contamination from one channel to another, and when combined with the ultra-low internal volumes of Systec AF™ channels needed for HPLC flow rates, all but eliminates this cross contamination concern by the chromatographer. Systec AF™ has been used in certain optical systems associated with HPLC for a few years without concern for normal HPLC solvents. However, Systec AF™ is soluble in certain solvents (see cautionary statements) and must not be used to degas these types of solvents.

Systec AF™ is permeable to some degree to water vapor whereas PTFE is not. While the vacuum pump in the Vacuum Degasser contains internal provisions for sweeping water or solvent vapor from the pump continuously, it is possible that over time, high concentration buffers may form crystals within the channel due to the loss of water within the channel. The same precautions should be taken to prevent crystallization within these channels as are taken for the HPLC pump. See the “Short-term Shutdown” procedures.

## Operating Summary

1. Select and fill each solvent reservoir with the mobile phase for your analysis.
2. Verify that the Vacuum Degasser is properly installed as described in "Setup."

CAUTION: Never connect the Vacuum Degasser to the output side of the HPLC pump. The high pressure may cause permanent damage to the degassing membrane.

3. Verify that the tubing to your injector, column and detector is properly connected. Also verify that plugs are installed in the unused ports.
4. Disconnect and remove the tubing that is connected to the output port, connect the priming syringe to this port, and pull the solvent through the degasser until bubbles no longer appear. Then reconnect the tubing to the output port.
5. Switch on the degasser and start the pump at 1.0 mL/min. Allow the system to equilibrate for 5-10 minutes. The small volumes contained in the Vacuum Degasser should only be considered in chromatograph equilibration time when flow rates less than 1 mL/min are used.

NOTE: Use of this product outside the scope of this manual may present a hazard.

### Extending the degassing flow rate range

Certain organic solvents used in reversed phase chromatography outgas upon mixing with water, if not properly degassed. These solvents are generally alcohols (e.g. methanol), acetonitrile and tetrahydrofuran. Passing water and methanol through a single channel is generally sufficient to degas these solvents so outgassing does not occur upon mixing when a 60:40 methanol/water mixture is generated by your Vacuum Degasser or pump at a flow rate of 3 mL/min. If outgassing does occur, or if a flow rate higher than 3 mL/min. is required, it is a general rule that only the organic portion of the mobile phase needs to be passed through a second degassing channel to ensure outgassing does not occur. This is due to the ability of all organic solvents (e.g. methanol) to hold at least 10 times more dissolved atmosphere than water can.

To more thoroughly degas a mobile phase, connect the outlet of the organic channel to the inlet a second channel and the outlet of the second channel to the pump. This places the two channels in series and doubles the degassing capacity for the organic portion of the mobile phase.

## Shutdown

There are two types of shutdown procedures: long-term and short-term.

### Short-term Shutdown (Overnight and Weekends)

Observe all precautions pertaining to hazardous solvents and/or those solvents that form harmful deposits or by-products.

1. Remove harmful mobile phases from the Vacuum Degasser and other instruments in the system.
2. Flush the column according to the instructions supplied with the column. Flush buffer salts from the system with water. Evaporation leaves salt crystals that may form harmful deposits. Remove chloroform or solvents that can decompose to form hydrochloric acid from the system.

CAUTION: Damage caused by precipitating buffer salts in capillary tubing, or damage resulting from this condition, is specifically excluded from warranty.

3. After removing harmful mobile phases, prepare the detector for most mobile phases by flushing it with isopropanol. **To avoid contaminating the system, refill or discard solvents (including water) that were exposed to the environment for more than 24 hours before use.**
4. For weekend storage we recommend flushing 60/40% MeOH/Water through the Vacuum Degasser, pump, column, flow cell (provided your column is compatible with MeOH/Water). Then turn off the Vacuum Degasser, pump and detector.

### Long-term Shutdown

1. Follow Short-term Shutdown procedure Steps 1 and 2.
2. Remove the column and direct the pump output tubing to a beaker. Flush the Vacuum Degasser, first with water and then with isopropanol.
3. Turn off the Vacuum Degasser. Then disconnect the tubing between the Vacuum Degasser and solvent reservoirs, and the Vacuum Degasser and pump. Plug all of the ports on the Vacuum Degasser.
4. Store the Vacuum Degasser in a clean, dry location.
5. Before using the Vacuum Degasser, completely purge it with the correct solvent for the column before reconnecting the column and restarting the system.

## Maintenance

You can experience long and trouble-free performance from your Vacuum Degasser by performing both routine and preventive maintenance procedures.

### Preventative Maintenance

Perform preventive maintenance to ensure that your Vacuum Degasser will perform consistently at an optimal level. To maintain the Vacuum Degasser in the best condition, the following measures are recommended:

1. Adhere to standard laboratory cleanliness practices.
  - Use only high-purity solvents (preferably HPLC Grade) for mobile phases. Water should be bottled HPLC Grade, or filtered and deionized tap water.
  - Filter all solvents to prevent particulate contamination and tubing blockages.
2. Use only high-purity gases when drying contact areas.
  - Ensure that all new tubing (stainless steel) is passivated and thoroughly flushed before making pump connections.
  - Follow the short- and long-term shutdown procedures that are described above.
3. Routine cleaning of the external surfaces of the instrument can be done using a clean, damp cloth. Immediately clean any spills which occur on or near the instrument using methods appropriate for the type of spill. Some solvents can damage the appearance and function of the instrument.

### Routine Maintenance

Routine maintenance is defined as replacing the normal wear items when you notice degradation in performance.

If you have a problem, you can save time and money by referring to the Troubleshooting Guide, below, before calling your Service Representative. Your problem may be minor, and you may be able to correct it yourself using the Troubleshooting Guide to pinpoint the cause.

**WARNING:** Never remove the Degasser's cover. There is nothing inside that requires customer service or maintenance.

## Troubleshooting Guide

<b>Problem</b>	<b>Probable Cause</b>	<b>Solution</b>
1) Power switch is on, but all 3 LEDs are off, indicating no power to the degasser.	1a) The AC Adapter is not plugged into the AC outlet. 1b) Blown fuse.	1a) Plug the AC Adapter into the AC outlet. 1b) Contact your Service Representative.
2) Yellow Status LED is on steadily, pump is running and RPM seems high.	2) Pump is in initial pull-down phase or system's degassing demand has increased.	2) Typically normal operation, although if pump speed continues to rise for an extended period of time (as heard by the pitch of the stepper motor) it could indicate a potential fault condition.
3) Yellow Status LED is flashing approximately 1 second off, 1 second on. Vacuum pump is not running.	3) Possible system leak.	3) Contact your Service Representative.
4) Yellow Status LED is flashing approximately 2 seconds off, 1 second on. Vacuum pump is not running.	4) Possible sensor or Control Board fault.	4) Contact your Service Representative.
5) Is there a way to check whether the system is operating correctly when Power and Vacuum green LEDs are illuminated, but pump can't be heard running?	5) Due to the design of the pump and degasser, the pump is virtually silent at low RPM, even though vacuum is good and degassing is normal.	5a) Place a hand on the top of the unit. A slight vibration can be felt indicating the pump is operating at low RPM. 5b) Monitor the UV absorbance of non-degassed methanol at 215 nM versus degassed methanol coming through the degasser. Proper performance of the degasser should decrease the UV absorbance of the methanol significantly.
6) Bubbles appear through the output tubing.	6) Loose fitting(s).	6) Tighten the input and output fittings.
7) No solvent flow.	7a) Air in the HPLC pump head. 7b) If a buffer solvent was left in the degasser for some time after use it may plug the degasser elements.	7a) Prime/purge the pump head. 7b) Use a different channel, or connect the channel to a beaker of the solvent without the buffer. Draw the solvent through the channel to dissolve the buffer. Do not push the solvent through the channel. If this flushing action does not work, contact your Service Representative.